

**FOR TREE LAWNS OF
LESS THAN 6'-0"**

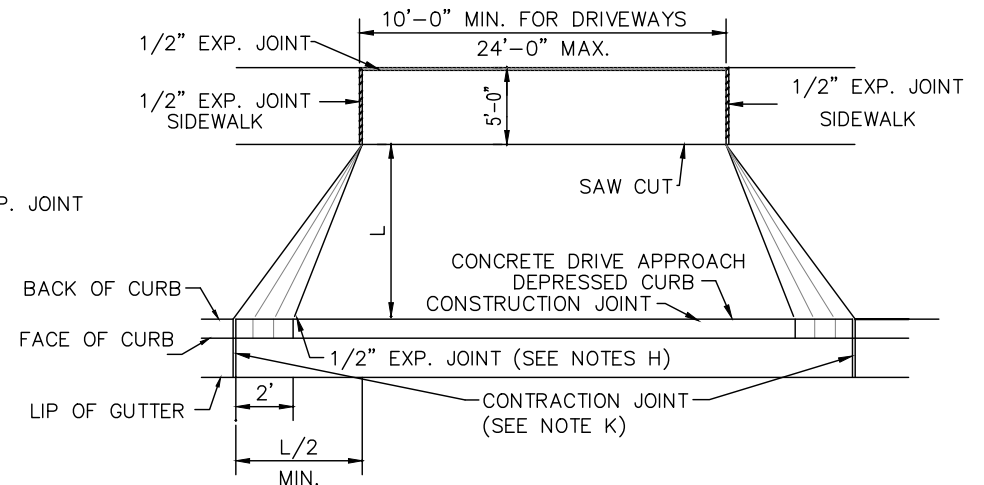
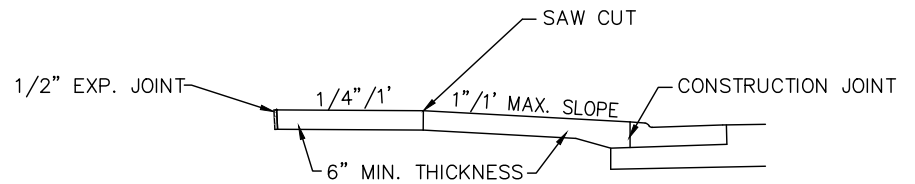

**FOR TREE LAWNS OF
6'-0" OR MORE**

NOTES

- A. DRIVE APPROACHES SHALL MEET THE REQUIREMENTS OF ODOT ITEM 452 AND 499 CAST-IN-PLACE CONCRETE.
- B. MAXIMUM JOINT SPACING SHALL BE 10' LONGITUDINALLY, TRANSVERSELY AND AT TAPERS.
- C. EXPANSION MATERIAL SHALL BE 1/2" PREMOLDED.
- D. 3" OF COMPACTED ODOT 304 AGGREGATE SHALL BE PLACED UNDER DRIVE APPROACHES IF DETERMINED NECESSARY BY THE CITY.
- E. PROVIDE BROOM FINISH AND EDGING TO ALL EXPOSED SURFACES.

- F. WHERE CURB AND GUTTER HAS NOT BEEN PROPERLY DROPPED AT DRIVE APPROACHES, THE CURB SHALL BE ENTIRELY REMOVED AND REPLACED TO THE NEAREST CONTRACTION JOINT BEYOND THE DRIVEWAY AND REPLACED BY EITHER THE CONTRACTOR OR THE OWNER. NO SAWCUTTING OF THE CURB IS PERMITTED.
- G. JOINTS SHALL BE CLEANED AND EDGED BY A 1/4" RADIUS EDGER. LONGITUDINAL JOINTS SHALL BE AS DIRECTED BY THE CITY. EXPANSION JOINTS SHALL BE OF SUCH DIMENSIONS AS SHOWN ON STANDARD DRAWINGS FOR CONSTRUCTION JOINTS.
- H. EXPANSION JOINT LOCATION MAY BE ALTERED WITH CITY APPROVAL.

- I. CONCRETE SHALL BE ODOT CLASS QC-1P (4000 PSI, 600 LB/CY) CEMENT. PROPORTIONING OPTIONS 1, 2, AND 3 NOT ALLOWED.
- J. CONCRETE SHALL CONTAIN 6% ± 1% OF TOTAL AIR.
- K. IF CURB IS REMOVED AND REPLACED DURING DRIVEWAY CONSTRUCTION, JOINTS BETWEEN EXISTING AND NEW CURB ARE TO CONTAIN 1/2" EXPANSION MATERIAL.
- L. A RIGHT-OF-WAY PERMIT IS REQUIRED FOR ANY AND ALL WORK IN THE RIGHT-OF-WAY INCLUDING A \$10 DRIVEWAY FEE, IF APPLICABLE, THROUGH THE ENGINEERING DEPARTMENT.



RESIDENTIAL DRIVE APPROACH

REVISIONS: 06-25-07 07-22-13	DATE APPROVED: 06/03/2020
PAGE No. 300-7	