

**TEMPORARY HAMMER HEAD**

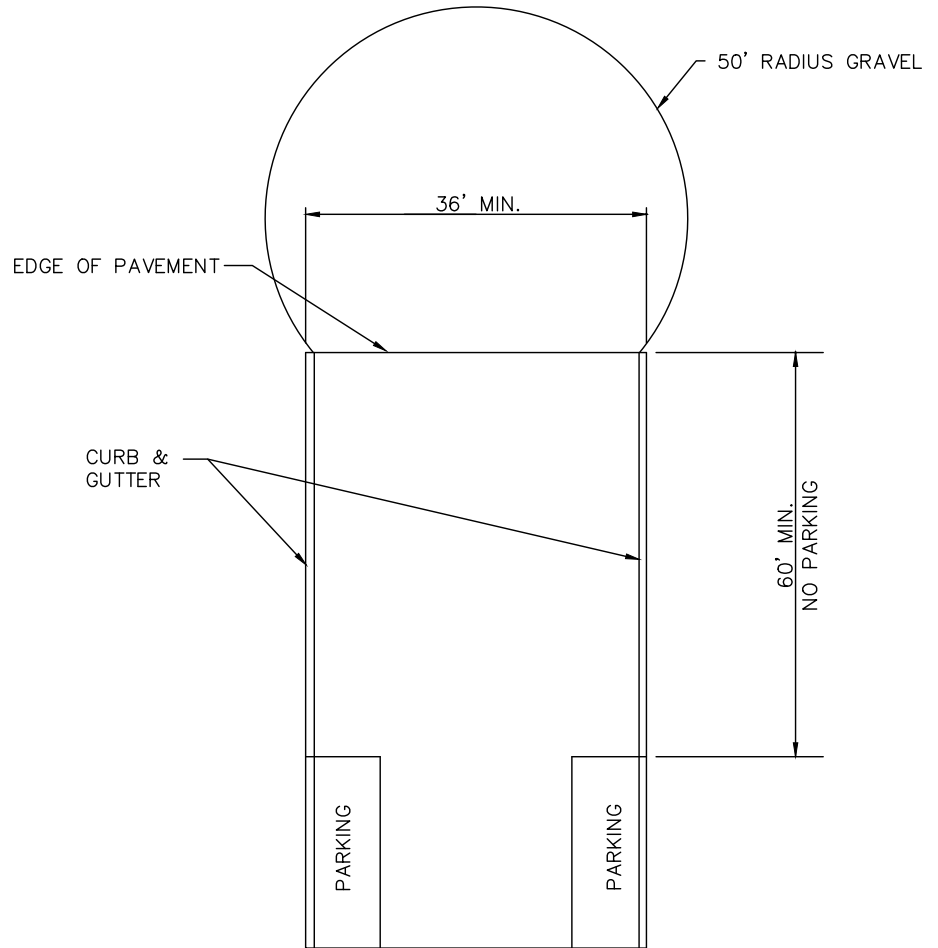

**TEMPORARY DEAD-END STREETS**

**NOTES**

A. TEMPORARY DEAD END STREETS ARE ONLY PERMITTED IN SITUATIONS WHERE EXTENSION OF ROADWAY IS PLANNED IN A PHASED DEVELOPMENT AND THE ADJOINING PHASE IS UNDER CONSTRUCTION OR BONDED FOR DEVELOPMENT. IF DEVELOPMENT OF THE NEXT PHASE IS NOT IMMEDIATE A GRAVEL CUL-DE-SAC IS REQUIRED TO BE INSTALLED AND MAINTAINED.



**CITY OF  
SIDNEY**

**TEMPORARY DEAD-END STREETS**

REVISIONS:  
02-24-03  
10-12-09  
07-22-13

DATE  
APPROVED:  
06/03/2020

PAGE No.  
300-4