

TYPICAL CROWN

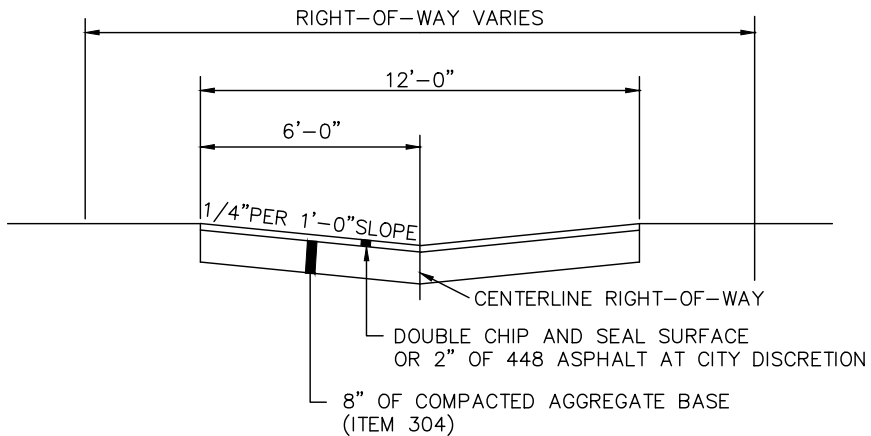

INVERTED CROWN

TYPICAL ALLEY CONSTRUCTION

- A. MINIMUM STANDARD (UNLESS OTHERWISE APPROVED).
- B. FOR RENOVATION OF EXISTING ALLEYS ONLY. NO NEW ALLEYS WILL BE APPROVED WITHIN THE CITY.

ADJACENT PARKING AREAS SHALL BE CONNECTED TO LIMIT THE NUMBER OF ACCESS DRIVES TO THE STREET.

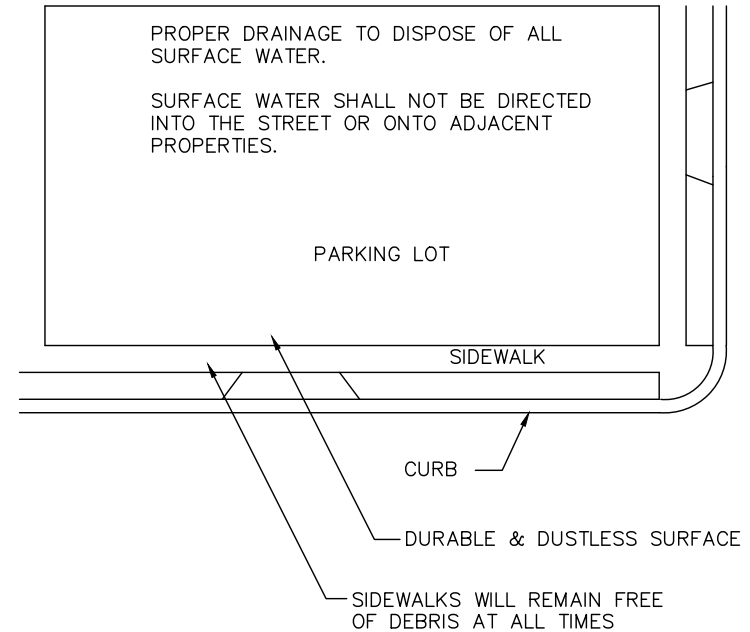

PARKING LOT DETAIL

THE FOLLOWING ARE ACCEPTED LOT SURFACES (UNLESS OTHERWISE APPROVED).

- A. DOUBLE CHIP AND SEAL, WITH APPROVAL.
- B. ASPHALT CONCRETE ITEM 448.
- C. CONCRETE.