

TYPE 3 SANITARY MANHOLE

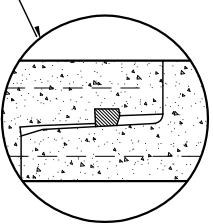

NOTES

- A.** SANITARY MANHOLE FRAMES AND COVERS SHALL BE EQUAL TO NENAH NO. R-1767 OR EAST JORDAN IRON WORKS NO. 1600. LID SHALL BE SANITARY LETTERED SOLID NON-VENTED, SELF-SEALING AND NON-BOLTED LIDS. NO LATERALS SHALL PROTRUDE INTO THE INTERIOR MANHOLE. VENTED LIDS ARE PERMITTED BASED UPON DESIGN AT LOCATIONS THAT ARE NOT SUBJECT TO INFLOW FROM SURFACE WATER.
- B.** TO CONNECT INTO EXISTING MANHOLE, THE MANHOLE SHALL BE CORED AND AN A-LOK XP SERIES FLEXIBLE CONNECTOR OR EQUIVALENT SHALL BE INSTALLED PER MANUFACTURER'S RECOMMENDATIONS. NON-SHRINK GROUT ALTERNATIVE MAY BE USED IN SPECIAL CIRCUMSTANCES WHEN PREVIOUSLY APPROVED BY CITY.
- C.** MATERIALS FOR BASES, RISERS, AND OTHER PRECAST SECTIONS, INCLUDING REINFORCEMENTS SHALL COMPLY WITH ASTM C-478.
- D.** MAXIMUM SANITARY MANHOLE SPACING SHALL BE 350' FOR LESS THAN 15", 400' FOR 15" AND GREATER.
- E.** LOCATE THE CENTERLINE OF MANHOLE COVERS OVER THE CENTERLINE OF THE MAIN SEWER WHENEVER POSSIBLE.
- F.** CUT PIPE SHALL NOT EXTEND BEYOND THE INSIDE FACE OF THE MANHOLE WALL.
- G.** CONCRETE PLACED INSIDE THE MANHOLE SHALL NOT BE PLACED BETWEEN THE PIPE AND THE OPENING SO AS TO INTERFERE IN ANY WAY WITH THE FLEXIBILITY OF THE JOINT.
- H.** (4) 3/4" DIA. STAINLESS STEEL ANCHOR BOLTS AND NUTS TO FASTEN MANHOLE FRAME TO MANHOLE CONE OR FLAT LID SECTION WHEN REQUIRED BY THE CITY ENGINEER.

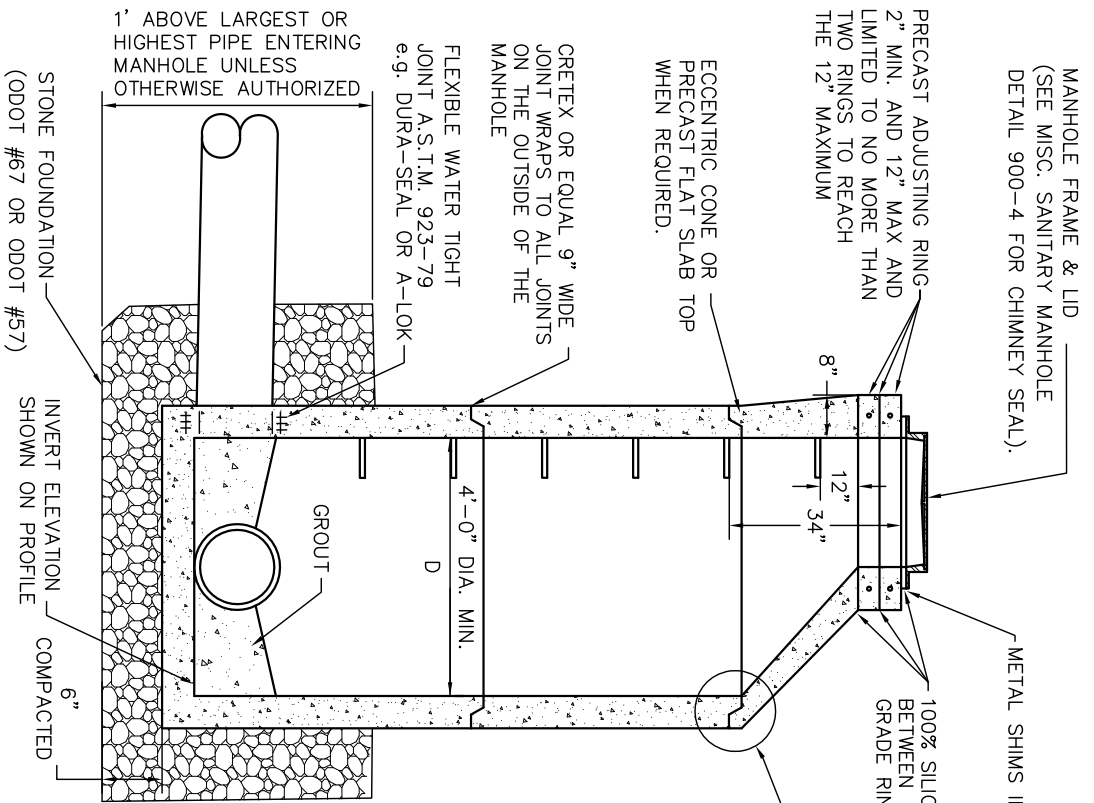
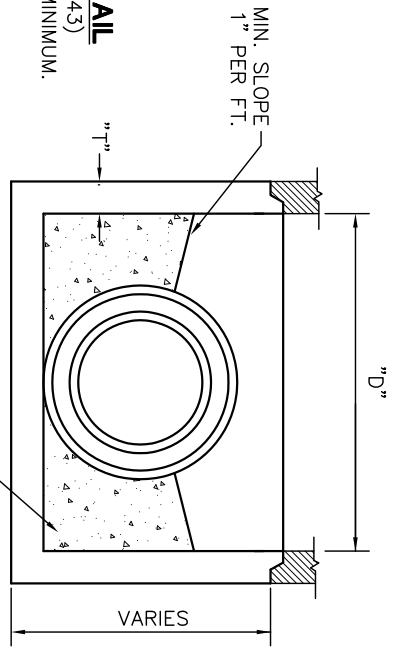

PRECAST BASE SECTION

PIPE SIZE	T	D
24" & UNDER	5"	48"
27" & ABOVE	6"	60"

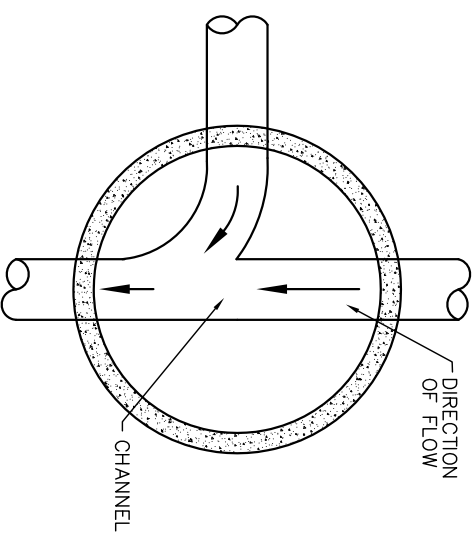

THE FLOW CHANNEL THROUGH MANHOLES SHALL BE MADE TO CONFORM IN SHAPE, SLOPE AND SMOOTHNESS TO THAT OF THE SEWERS.

STANDARD INVERT CHANNEL

ALL INVERTS TO BE CHANNELLED FOR OPTIMUM FLOW.

REVISIONS:
10-12-09
11-05-12
07-22-13

DATE
APPROVED:
FEB. 2002
PAGE No.